

SECTION : 3A

AUTOMATIC TRANSAXLE DRIVE AXLE

TABLE OF CONTENTS

SPECIFICATIONS	3A-1	ON-VEHICLE SERVICE	3A-4
FASTENER TIGHTENING		DRIVE AXLE ASSEMBLY	3A-4
SPECIFICATIONS	3A-1	UNIT REPAIR	3A-8
SPECIAL TOOLS	3A-2	OUTER JOINT SEAL	3A-8
SPECIAL TOOLS TABLE	3A-2	INNER TRIPOT SEAL	3A-9
COMPONENT LOCATOR	3A-2	GENERAL DESCRIPTION AND SYSTEM	
FRONT DRIVE AXLE	3A-2	OPERATION	3A-13
MAINTENANCE AND REPAIR	3A-4	FRONT DRIVE AXLE	3A-13

SPECIFICATIONS

FASTENER TIGHTENING SPECIFICATIONS

Application	N·m	Lb·Ft	Lb·In
Axle Shaft Caulking Nut Initial Torque	180	134	–
Axle Shaft Caulking Nut Final Torque	50 + 60°	37 + 60°	–
Lower Ball Joint Nut and Bolt	60	44	–
Tie Rod Nut	60	44	–
Wheel Nuts (Steel Wheel)	90	66	–

SPECIAL TOOLS

SPECIAL TOOLS TABLE

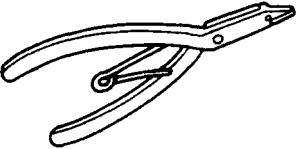
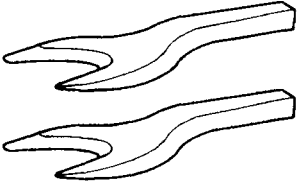
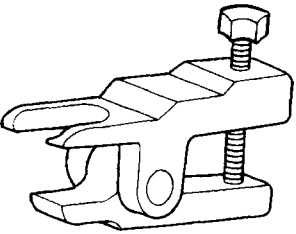
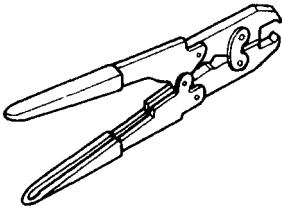
 <p>A104A001</p>	<p>J-8059 Snap Ring Pliers</p>	 <p>A106C032</p>	<p>KM-460-A Axle Shaft Remover</p>
 <p>A106C034</p>	<p>KM-507-B Ball Joint Separator</p>	 <p>A104A008</p>	<p>J-35566 Seal Clamp Pliers</p>

COMPONENT LOCATOR

FRONT DRIVE AXLE

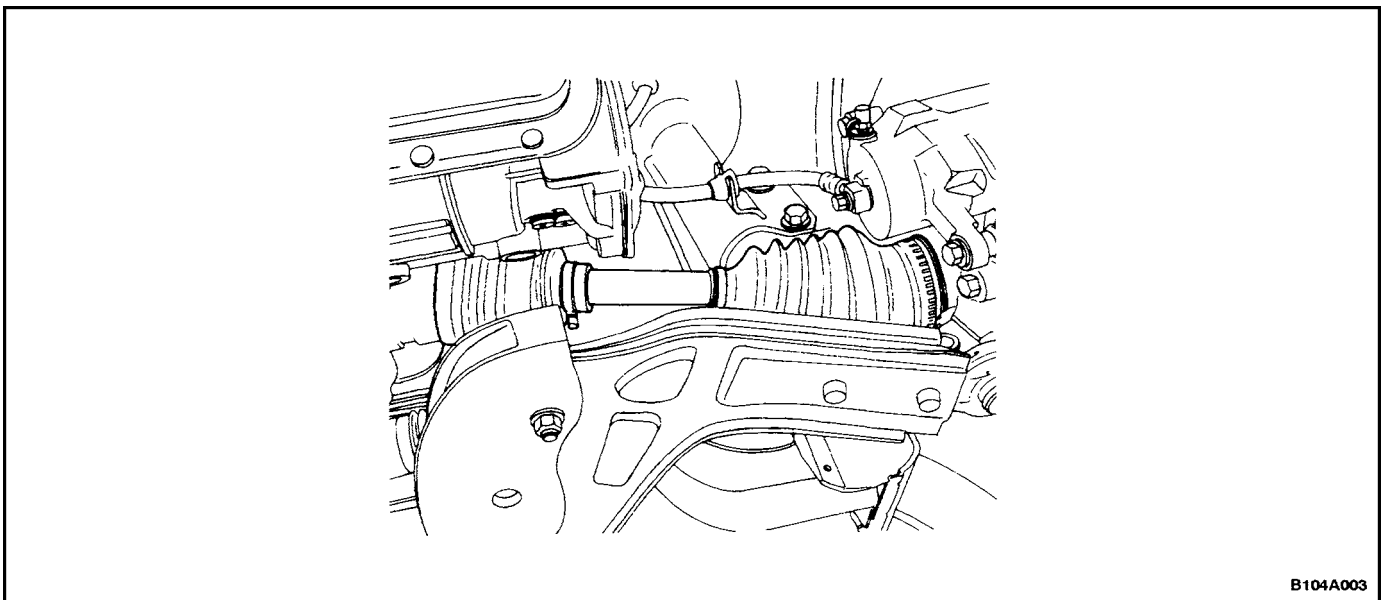

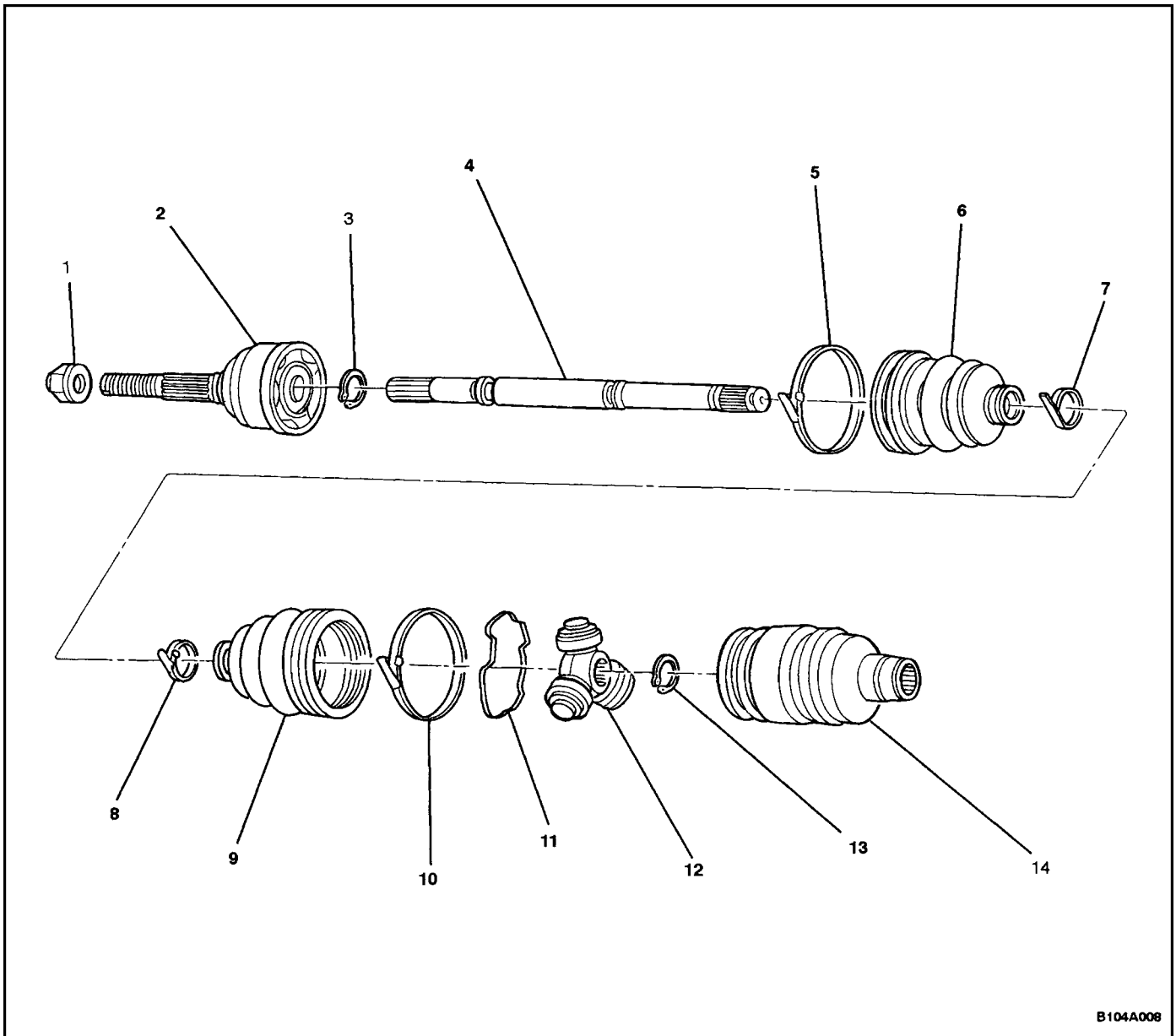

B104A008

- | | |
|-----------------------------------------------------|---------------------------------|
| 1. Caulking Nut | 8. Seal Retaining Clamp |
| 2. C/V Joint | 9. Drive Axle Inboard Seal |
| 3. Snap Ring | 10. Seal Retaining Clamp |
| 4. Axle Shaft (right-hand shown, left-hand similar) | 11. Tripot Joint Retaining Ring |
| 5. Seal Retaining Clamp | 12. Tripot Joint |
| 6. Drive Axle Outboard Seal | 13. Shaft Retaining Ring |
| 7. Seal Retaining Clamp | 14. Tripot Housing |

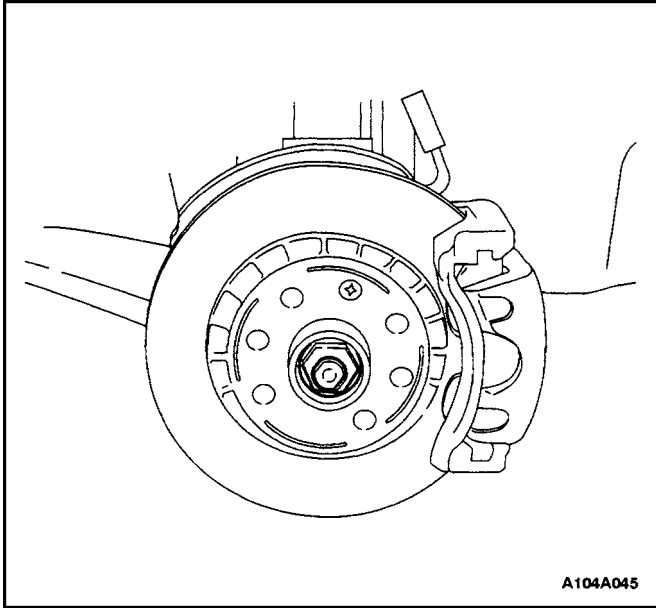

MAINTENANCE AND REPAIR

ON-VEHICLE SERVICE

DRIVE AXLE ASSEMBLY

Tools Required

KM-507-B Ball Joint Separator
KM-460-A Axle Shaft Remover

Removal Procedure

1. Raise and suitably support the vehicle.
2. Remove the wheels. Refer to *Section 2E, Tires and Wheels*.
3. Remove the engine under covers. Refer to *Section 9N, Frame and Underbody*.
4. Remove the axle shaft caulking nut. Discard the nut.
5. Remove the lower ball joint nut and bolt.

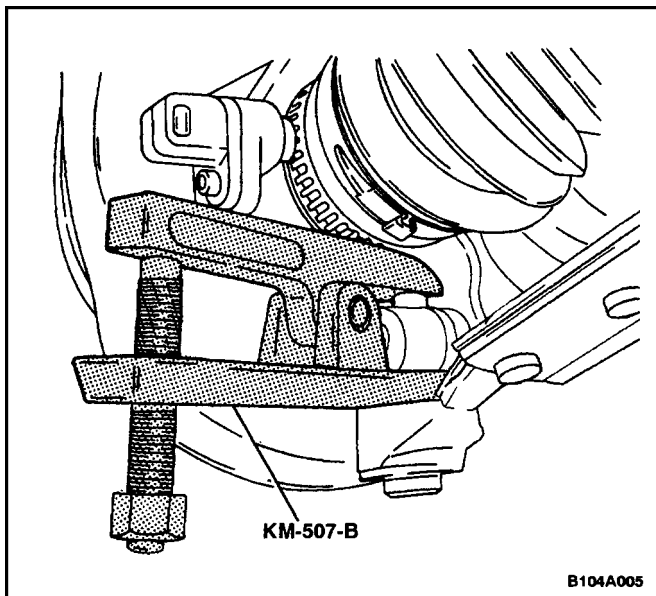
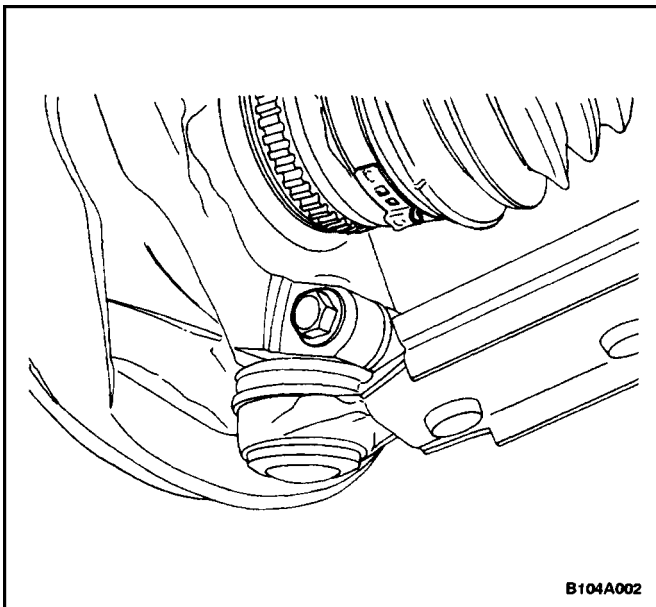

Notice : Use only the recommended tool for separating the lower ball joint. Failure to use the recommended tool may cause damage to the ball joint and the seal.

6. Separate the steering knuckle from the lower ball joint using the ball joint separator KM-507-B.

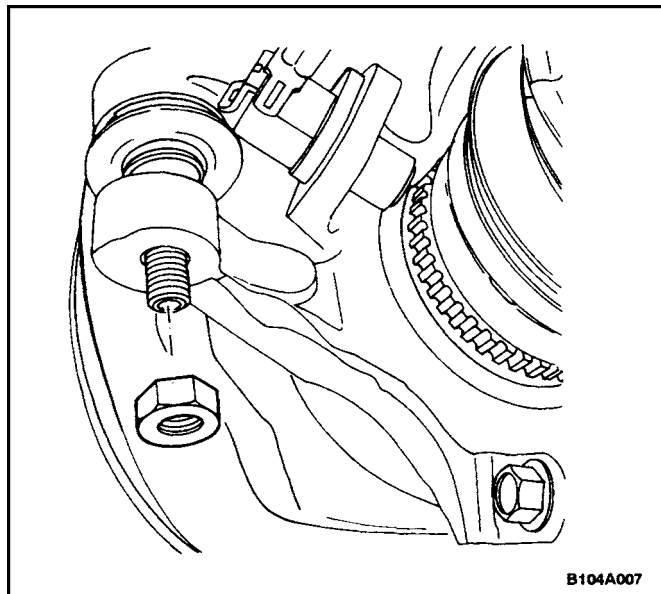

7. Remove the tie rod nut.

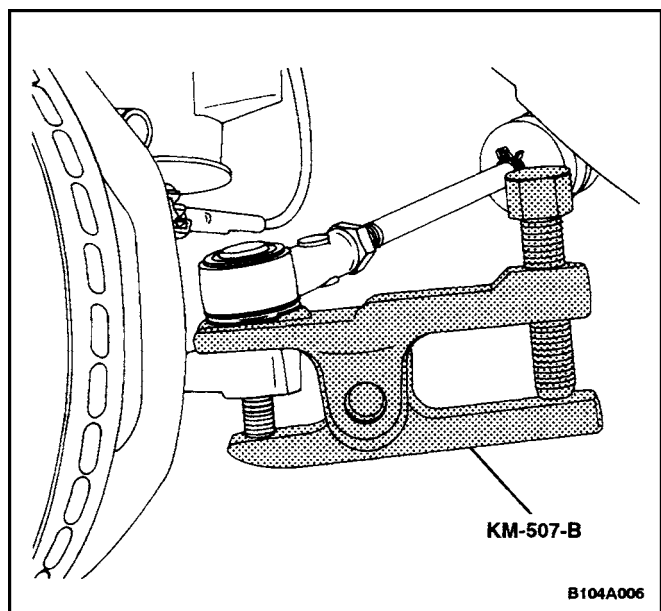

Notice : Use only the recommended tool for separating the tie rod from the knuckle/strut assembly. Failure to use the recommended tool may cause damage to the knuckle/strut assembly.

8. Separate the tie rod end using the ball joint separator KM-507-B.

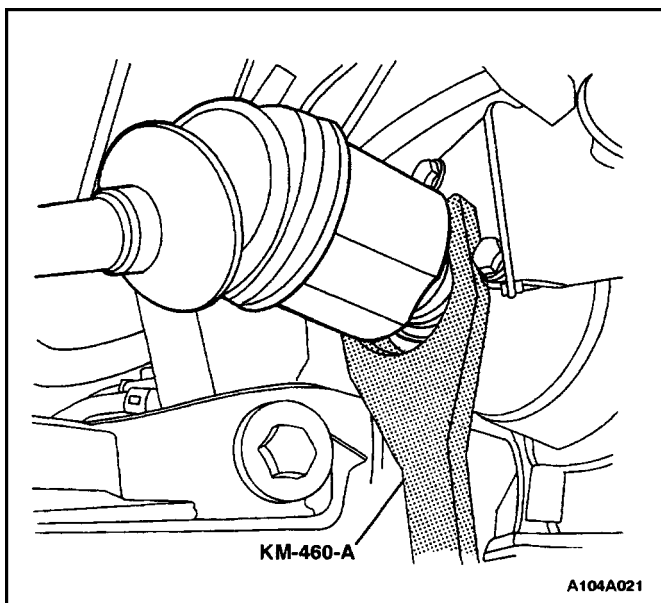

9. Push the drive axle shaft from the wheel hub.

Important : Support the unfastened end of the drive axle. Do not allow the drive axle to dangle freely from the transaxle for any length of time after it has been removed from the wheel hub.

Important : Place a drain pan below the transaxle to catch the escaping fluid. Cap the transaxle drive opening after the drive axle has been removed to keep the fluid in and any contamination out.

10. Remove the drive axle from the transaxle using the axle shaft remover KM-460-A.

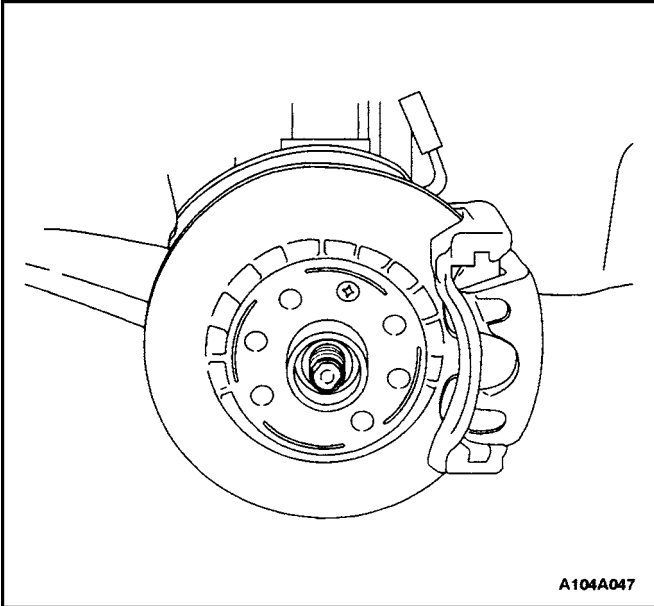

Installation Procedure

Notice : Do not damage the seals.

1. Clean the hub seal and the transaxle seal.
2. Install the drive axle into the transaxle.
3. Install the wheel hub onto the axle shaft.

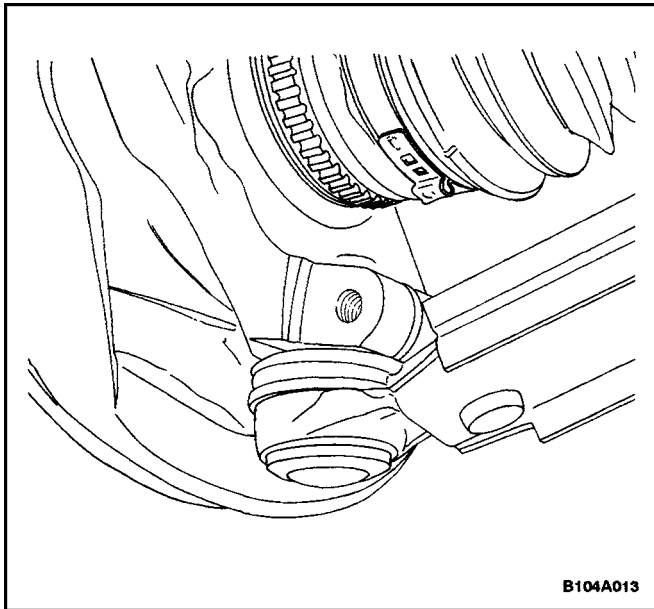

4. Mount the steering knuckle onto the lower ball joint.

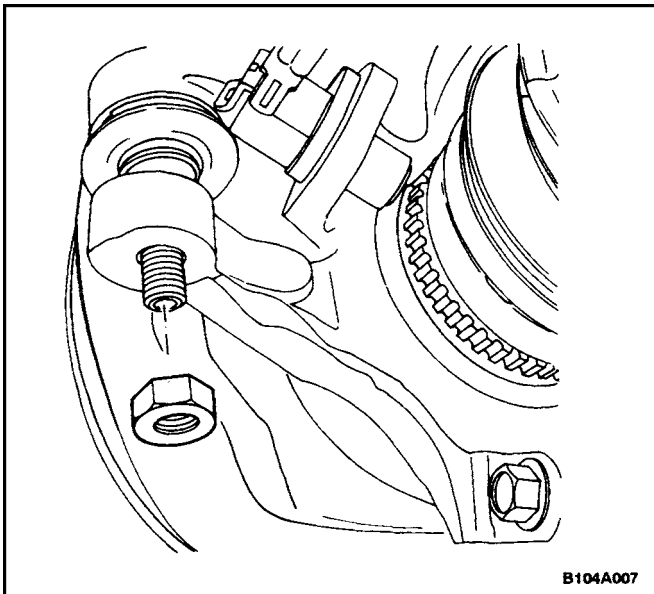

5. Install the tie rod into the knuckle/strut and install the tie rod nut.

Tighten

Tighten the tie rod nut to 60 N·m (44 lb-ft).

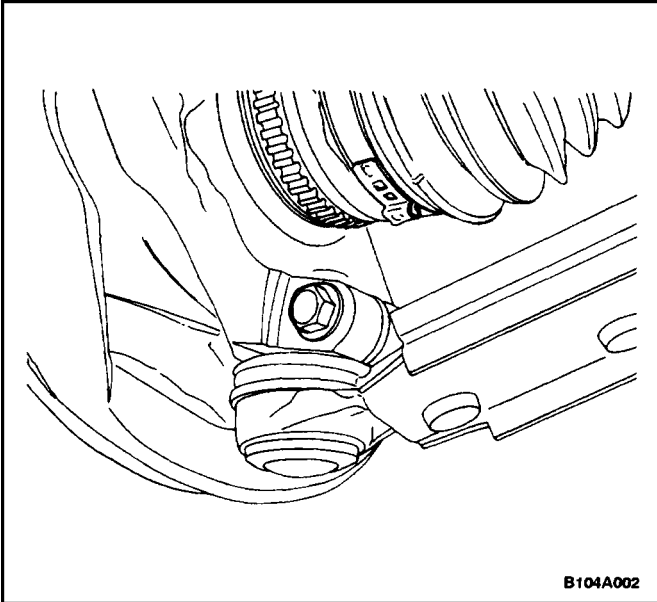

B104A002

6. Install the lower ball joint bolt and nut.

Tighten

Tighten the lower ball joint bolt and nut to 60 N·m (44 lb–ft).

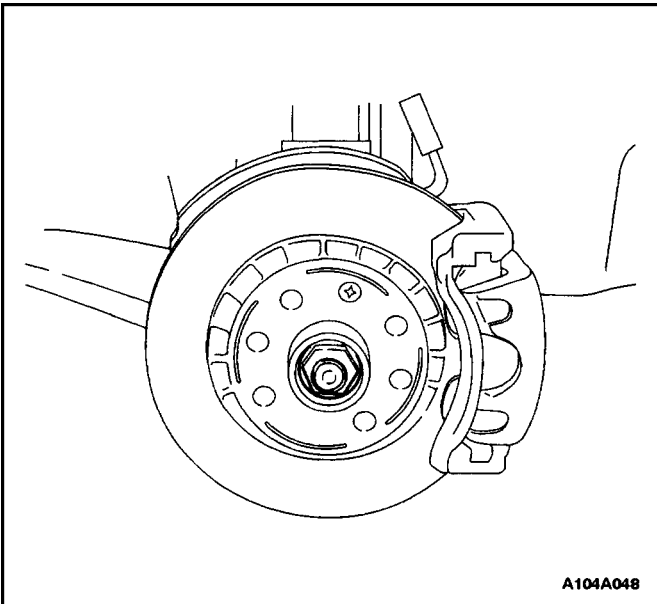

A104A048

7. Loosely install a new axle shaft caulking nut. Always use a new nut.
8. Install the wheels. Loosely install the bolts. Refer to *Section 2E, Tires and Wheels*.
9. Lower the vehicle to the floor.

Tighten

Tighten the wheel bolts to 90 N·m (66 lb–ft).

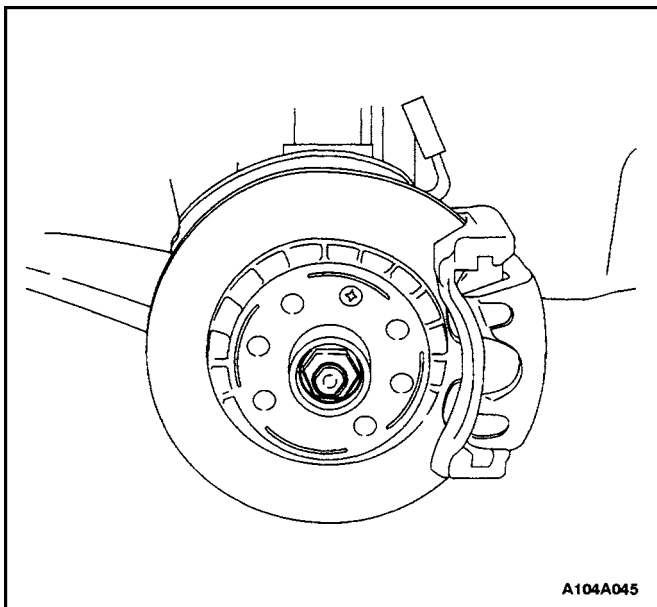

A104A045

10. Tighten the axle shaft caulking nut to 180 N·m (134 lb–ft). Loosen the nut and re-tighten the nut to 50 N·m (37 lb–ft). Then tighten the nut further by 60 degrees.
11. Peen the caulking nut with a punch and a hammer until the nut is locked into place on the axle shaft hub.
12. Install the engine under covers. Refer to *Section 9N, Frame and Underbody*.
13. Refill the transaxle fluid to the proper level. Refer to *Section 5A, 4T40E Automatic Transaxle*.

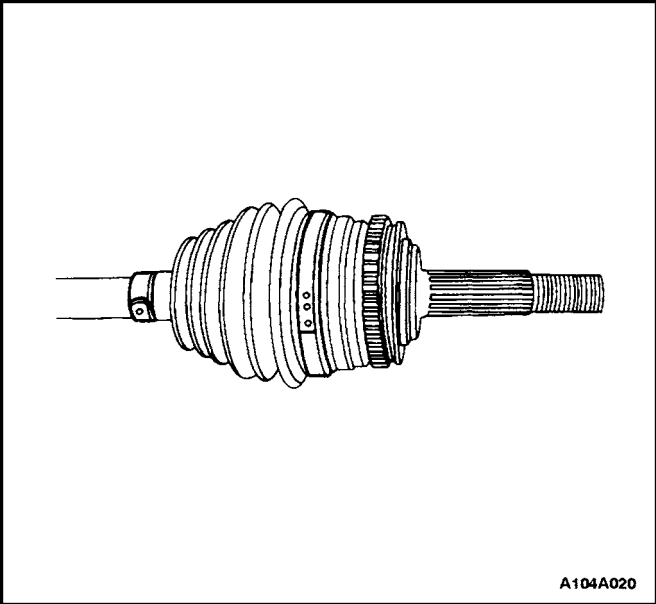

A104A020

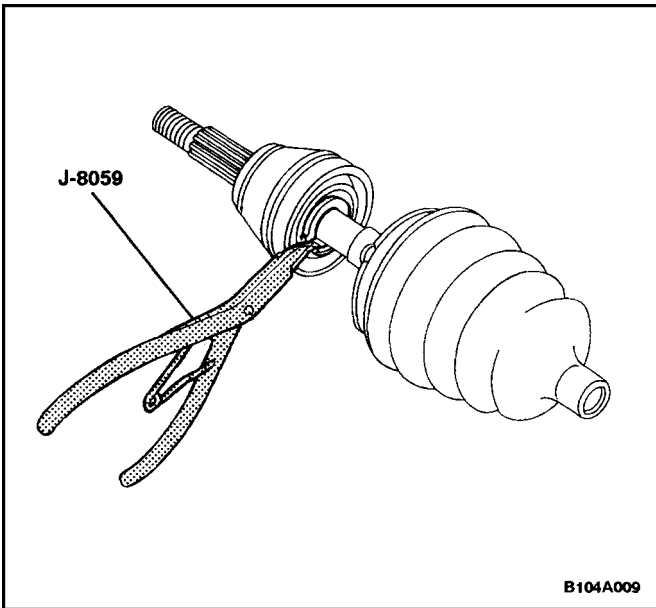

B104A009

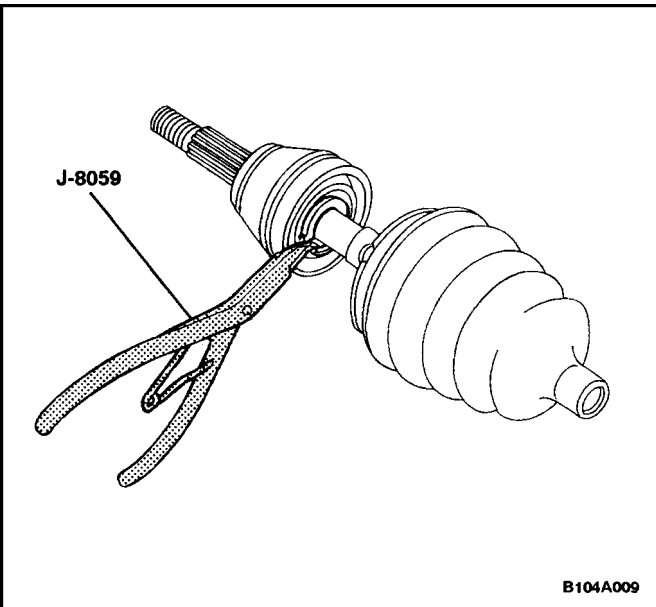

B104A009

UNIT REPAIR

OUTER JOINT SEAL

Tools Required

J-8059 Snap Ring Pliers

Removal Procedure

1. Remove the drive axle from the vehicle. Refer to "Drive Axle Assembly" in this section.
2. Remove the large seal retaining clamp. Discard the clamp.
3. Remove the small seal retaining clamp. Discard the clamp.

4. Degrease the joint.
5. Spread the snap ring using the snap ring pliers J-8059 and remove the outer joint from the axle shaft.

CAUTION : Do not disassemble the outer joint assembly. Parts are match fit and cannot be serviced separately. Improper reassembly will adversely affect both performance and safety.

6. Remove the seal from the joint assembly.

Installation Procedure

Tools Required

J-35566 Seal Clamp Pliers

1. Install the seal onto the axle shaft.
2. Spread the snap ring using the snap ring pliers J-8059 and install the outer joint onto the axle shaft.
3. Fill the joint seal with 175 to 195 g (6.2 to 6.9 ounces) of the recommended grease. Repack the joint with 175 to 195 g (6.2 to 6.9 ounces) of the recommended grease.

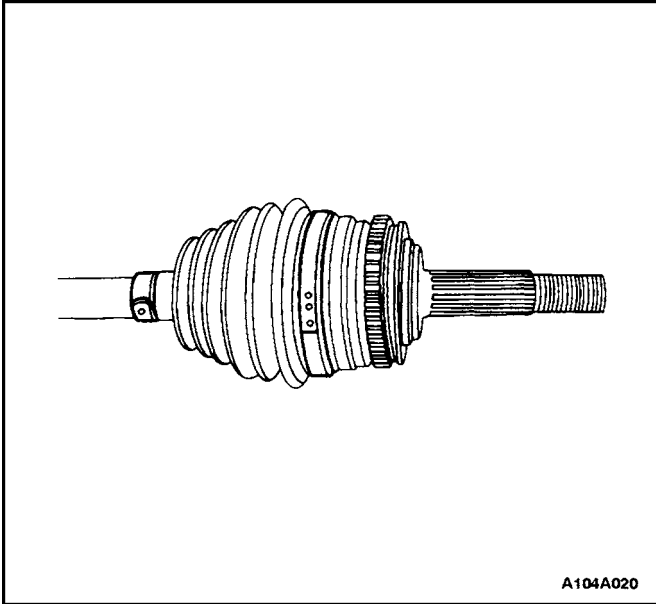

4. Install a new large seal retaining clamp and a new small seal retaining clamp.

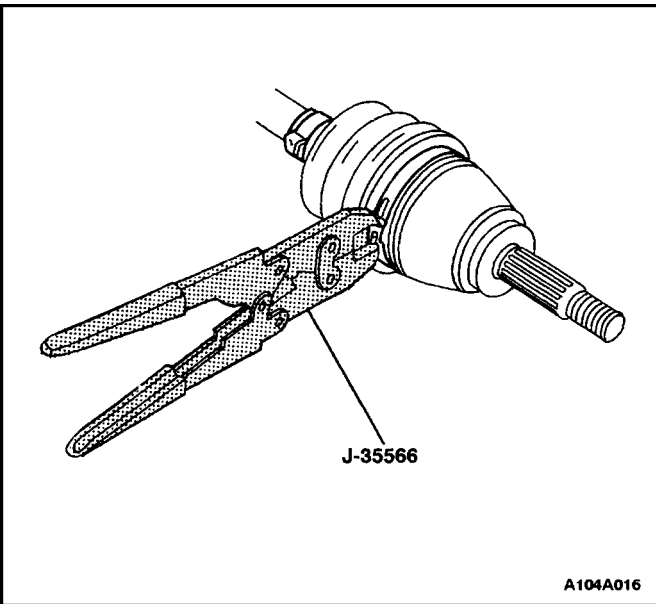

5. Crimp the new small seal retaining clamp and the new large seal retaining clamp using the seal clamp pliers J-35566.
6. Install the drive axle shaft to the vehicle. Refer to "Drive Axle Assembly" in this section.

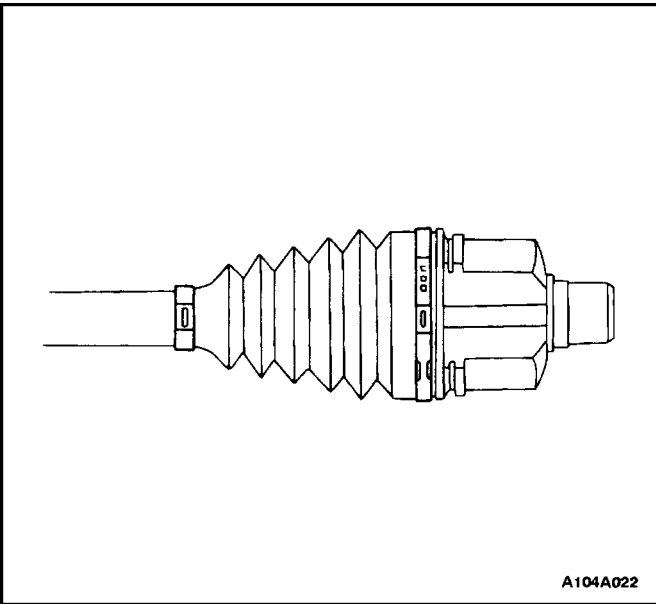

INNER TRIPOT SEAL

Tools Required

J-8059 Snap Ring Pliers

Removal Procedure

1. Remove the drive axle from the vehicle. Refer to "Drive Axle Assembly" in this section.
2. Remove the large seal retaining clamp. Discard the clamp.
3. Remove the small seal retaining clamp. Discard the clamp.

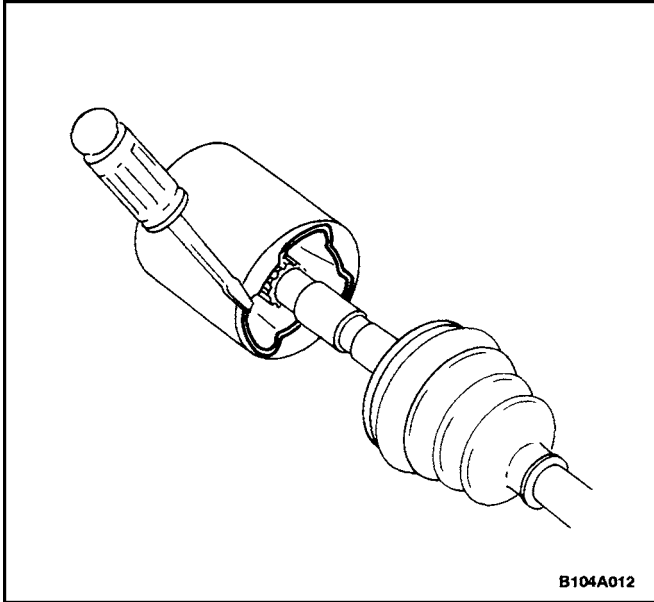

4. Pry the tripot joint retaining ring from the tripot housing.

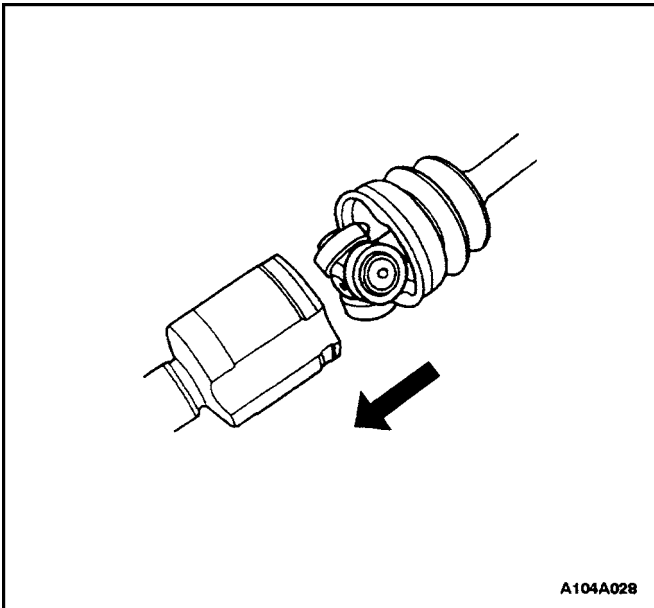

5. Remove the tripot housing from the seal.

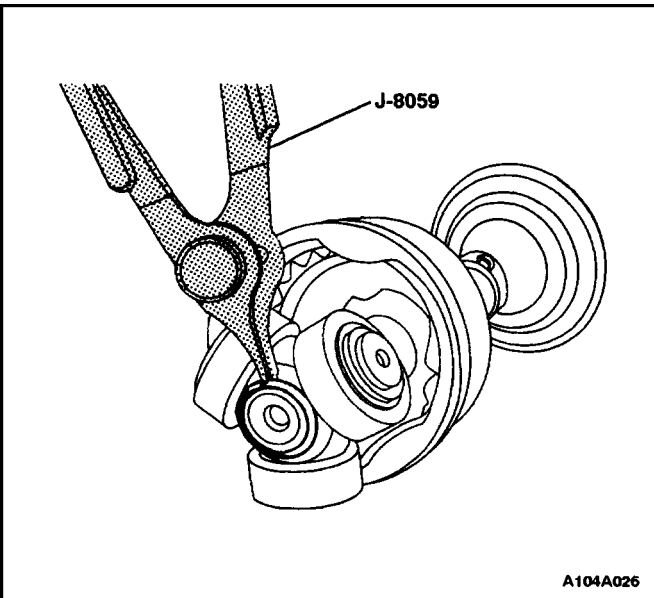

6. Degrease the tripot assembly.
7. Remove the shaft retaining ring using the snap ring pliers J-8059.

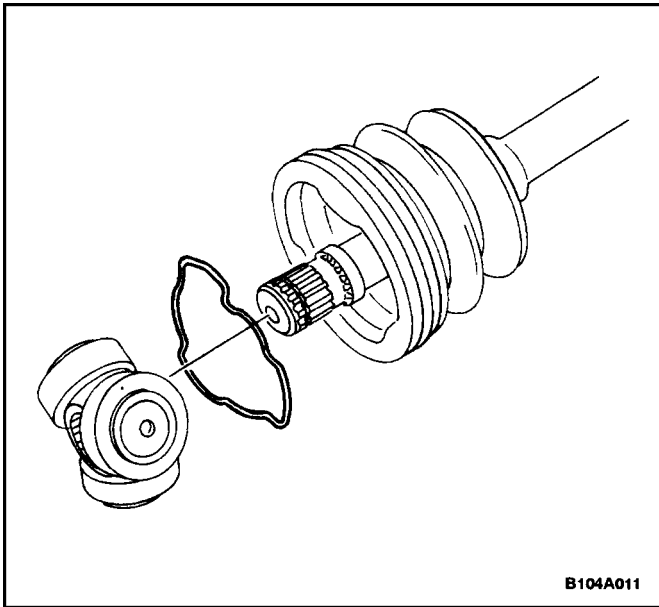

8. Remove the tripot and the tripot joint retaining ring from the axle shaft.
9. Remove the tripot joint seal from the axle shaft.

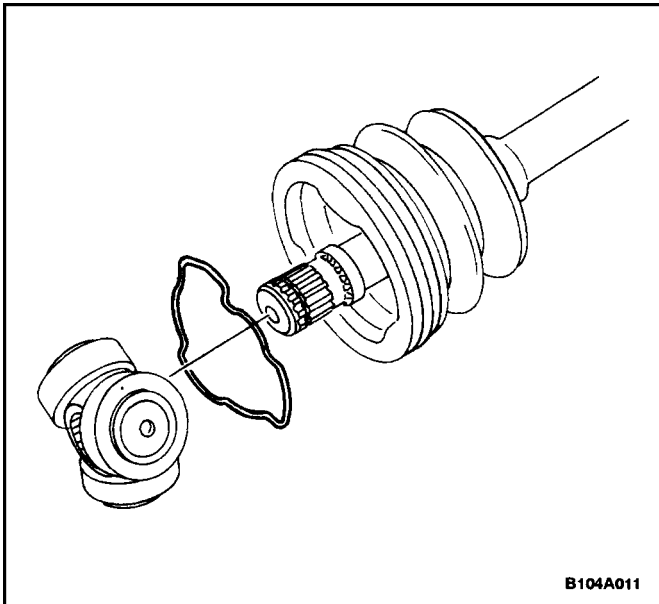

Installation Procedure

Tools Required

J-35566 Seal Clamp Pliers

1. Install a new small seal retaining clamp onto the seal. Do not crimp the seal retaining clamp.
2. Install the seal onto the axle shaft.
3. Install the tripot joint retaining ring and the tripot onto the axle shaft.

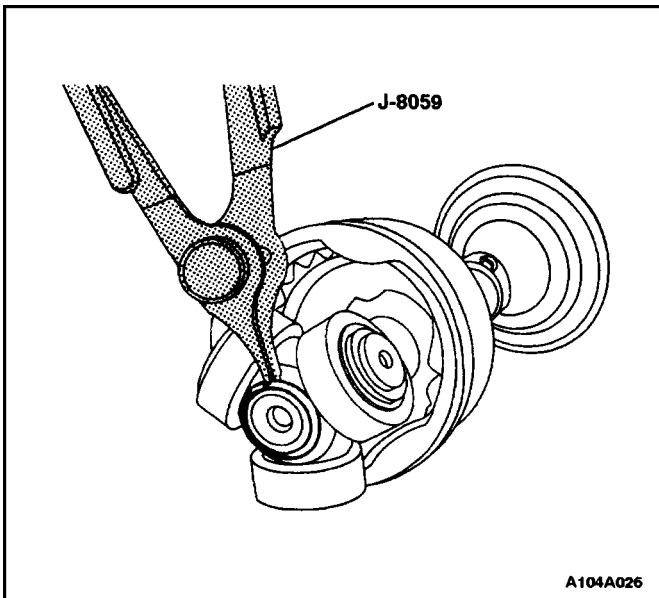

4. Install the shaft retaining ring onto the axle shaft using the snap ring pliers J-8059.

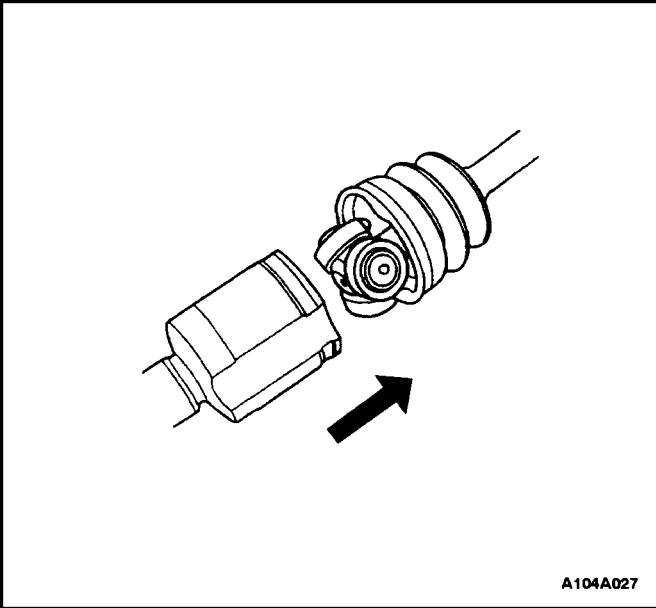

5. Fill the tripot housing with 195 to 215 g (6.9 to 7.6 ounces) of the recommended grease. Repack the tripot with 195 to 215 g (6.9 to 7.6 ounces) of the recommended grease.
6. Install the tripot housing onto the tripot assembly.

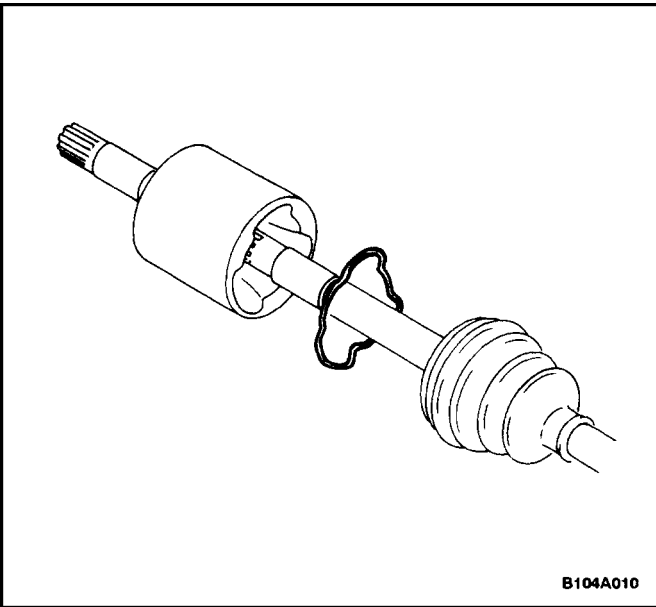

7. Install the tripot joint retaining ring into the tripot housing.

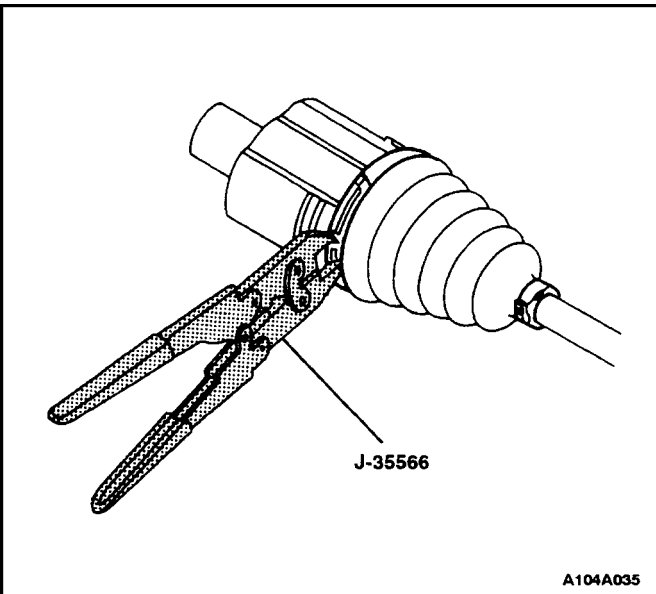

8. Install a new large seal retaining clamp. Crimp the large seal retaining clamp using the seal clamp pliers J-35566.
9. Crimp the new small seal retaining clamp using the seal clamp pliers J-35566.
10. Install the drive axle shaft to the vehicle. Refer to "Drive Axle Assembly" in this section.

GENERAL DESCRIPTION AND SYSTEM OPERATION

FRONT DRIVE AXLE

General Description

Drive axles are flexible shaft assemblies that transmit rotational force from the transaxle to the front-wheel assemblies. Each axle assembly consists of an inner and an

outer constant-velocity joint connected to an axle shaft. The inner joint is completely flexible and has the ability to move in and out. The outer joint is also flexible, but it cannot move in and out.

The drive axles use one type of outboard joint and one type of inboard joint. The inboard ends of both drive axles incorporate a female spline that installs over a stub shaft protruding from the transaxle.